

DRM Radio Tuner

Overview

DRM Tuner Chip is a proposed single chip implementation of the amplifier / channel filter and the LO frequency synthesizer for the application in the DRM digital audio broadcast receiver. It is also intended to support the present FM/AM broadcast as well as the extended DRM+ broadcast system. The single chip RF solution reduces the number of components in the RF module of the radio receiver as well as reducing the manual tuning requirements in the traditional radio manufacturing process. The chip provides a cost effective solution to the consumer terrestrial audio broadcast receivers: walkman type radio or kitchen radio.

The proposed single chip implementation of the Radio Tuner will consist 2 major blocks : a complex channel filter and an agile traditional PLL with fractional reference frequency programmability.

a/ Complex Channel Filter

Analog technique is employed to implement a complex bandpass filter to meet the channel filtering requirements of the DRM receiver system. The filter can be switched between a 10KHz passband centered at 25KHz for the operation of DRM30 / AM mode and a 100KHz passband centered at 250KHz for the FM operation. This operation can be used for the new DRM+ operation as well. The prototype results of the channel filter block and the targeted system performance are summarised in Table 1.

b/ Traditional PLL with fractional reference frequency programmability

A traditional PLL was modified so the the Prescaler division ratio can be controlled by a random single bit Σ - Δ sequence. The time average of the Σ - Δ bit sequence provides a fractional Prescaler division ratio. The PLL will force the output of this prescaler to be in lock with the master counter output of the reference frequency. The VCO output , at the input of the Prescaler, will therefore have a frequency equal to the phase detecting frequency multiplied by the fractional Prescaler division ratio. In this way a fine frequency resolution is achieved.

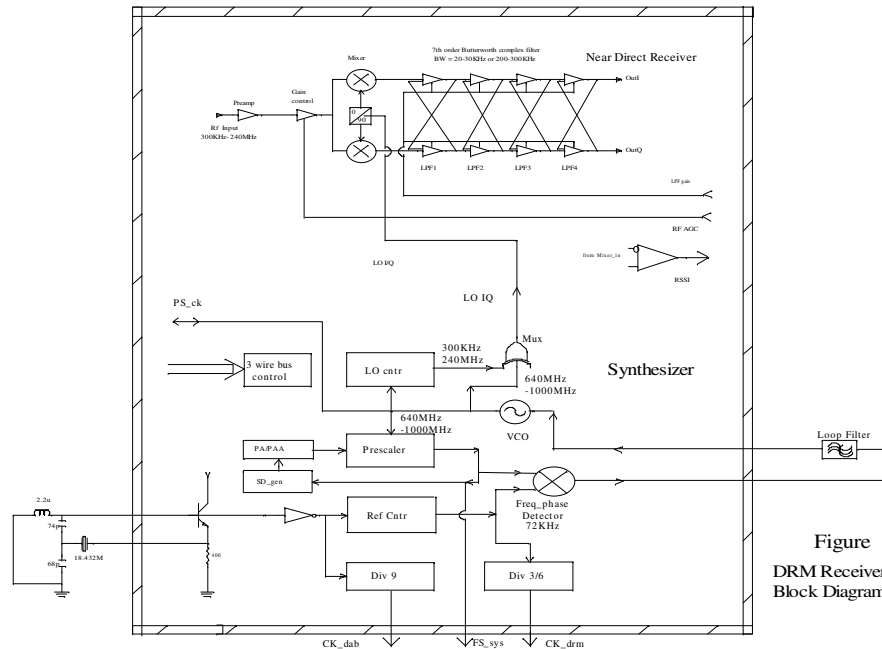
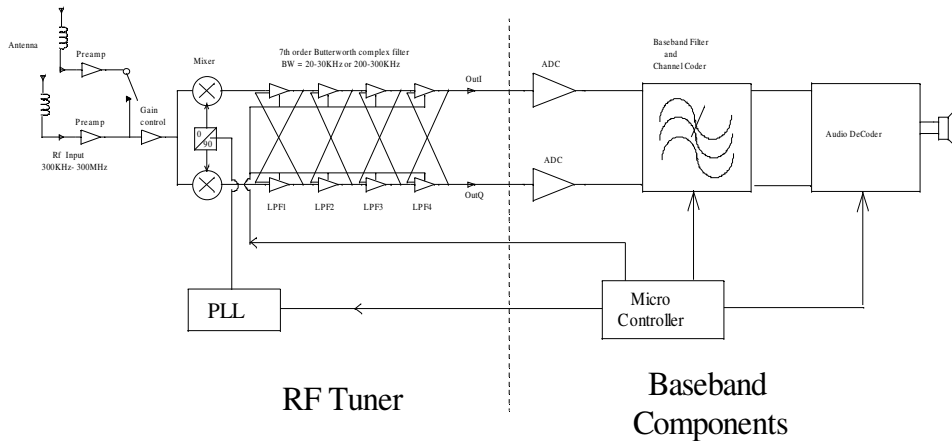

Figure 1
DRM Receiver
Block Diagram

Table 1 Specification (Target Parameters and Prototype Results)

Parameters	Conditions	Target	Prototype
DRM mode	300KHz - 30MHz		DRM30
DRM+ mode	30MHz - 174MHz		need improve LO range
FM	BAND II 88MHz - 108MHz		need external FM demod
AM	300KHz - 30MHz		need external AM demod
DAB	174MHz - 240MHz		Not yet implemented
Sensitivity	DRM 30 / AM (BW=10KHz)	-122dBm	-93dBm (@ mixer input)
S/N @ max sensitivity	FM / DRM+ (BW=100KHz)	-113dBm	12-18dB
Maximum Input Signal		>-15dBm	TBD
			-15dBm
Selectivity	Adjacent channel	33dB	TBD
	Far-off selectivity	>50dB	45dB
Gain adjustment	Linear range	80dB	78dB
Gain adjustment	with max image reject ratio		30dB
Signal band selection	select AM/FM/DRM/DRM+ signal	through different preamp and antenna	
Programmable step	in DRM 30 mode (< 30MHz)	2Hz	2Hz
Supply voltage		2-3.3V	>2.05
Current consumption		<100ma	65ma

Figure 2 External components for the proposed RF tuner



Smart Design

Unit 295B Wenta Business Center
Colne Way, Watford,
Hertfordshire WD24 7ND
United Kingdom

Tel: UK(0)1923-693797
Email: kwkwan@smartdesign-ic.com